

## High Purity Ball Valves M3HP True Bore (2½" - 4" ASME BPE | DN 65-100 DIN)

### DESCRIPTION

M3HP three piece body ball valves are isolating valves designed for use with clean steam, condensate and other gases and liquids used in high purity and aseptic processes. The valve is not designed as a control valve and should only be used as an isolating valve, fully open or fully closed. The product is mainly designed for the pharmaceutical, biotech, semiconductor, cosmetics, fine chemical, food and beverage industries.

### MAIN FEATURES

1. True bore floating ball design
  2. Completely made from solid bar stock material
  3. Can be serviced without removal from pipeline
  4. Bidirectional
  5. Anti blow out proof stem
  6. Tube weld with loose body flanges (360° rotation after installation)
- ISO 5211 mounting (only sizes ≥1")

### STANDARD SURFACE FINISH

**Internal wetted parts:** ≤ 0,51 micron Ra . SF1.

**External :** ≤ 0,76 micron Ra . SF3.

**Ultrasonic cleaning**



#### CE MARKING (PED – European Directive)

PN40	Category
2½" to 4"	1 (CE marked)

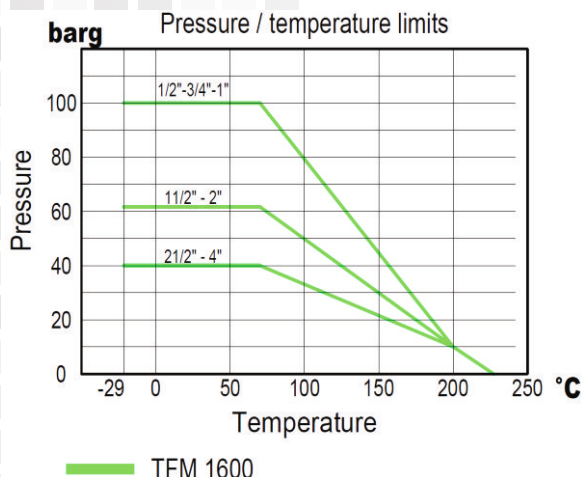

#### OPTIONS:

Antistatic device.  
Different sealing materials.  
Degreased for oxygen use.  
Cavity filler.

#### USE:

Clean steam, gases and liquids compatible with the construction.

#### AVAILABLE MODELS:

**SIZES:**

M3HP – Complete bar stock construction.  
2½" to 4".

#### CONNECTIONS:

According to ASME BPE.  
TC – Sanitary clamps.  
ETO – Extended tube orbital welding.  
TC / ETO – Combination.

#### PACKAGING:

Assembling and packaging in a clean room certified according to ISO 14644-1. The product is end capped and sealed with recyclable thermo-shrinkable plastic film, to avoid contamination.

#### INSTALLATION:

See IMI, installation and maintenance instructions.

## High Purity Ball Valves M3HP True Bore (2½" - 4" ASME BPE | DN 65-100 DIN)

### MATERIALS

POS. Nº	DESIGNATION	MATERIAL
1	Valve body	AISI 316L / 1.4404
2	TC end connection	AISI 316L / 1.4404
3	Tube weld end connection	AISI 316L / 1.4404
4	Flange	AISI 316L / 1.4404
5	Stem	AISI 316L / 1.4404
6	* Valve ball	AISI 316L / 1.4404
7	* Standard seat	TFM 1600
8	* Cavity filler seat	TFM 1600
9	Body ring	AISI 316L / 1.4404
10	* Body seal	PTFE
11	* Stem seals	TFM 1600
12	* Spacer	AISI 316 / 1.4401
13	Handle	AISI 304 / 1.4301
14	Handle end	Vinyl
14	Handle end (optional)	AISI 316L / 1.4404
15	Compression nut	AISI 304 / 1.4301
16	* Spring washers	AISI 304 / 1.4301
17	* Lock washer	AISI 304 / 1.4301
18	Fixing bolt	AISI 304 / 1.4301
19	Stop pin	AISI 304 / 1.4301
20	Handle stopper	AISI 304 / 1.4301
21	Fixing screw	AISI 304 / 1.4301
22	** Antistatic device	AISI 316 / 1.4401
23	O-ring	Viton

\* Available spare parts. \*\* On request.  
FDA / USP Class VI seals certificate on request.  
All valves have a serial number. In case of non standard valves this number must be supplied if spare parts are ordered.

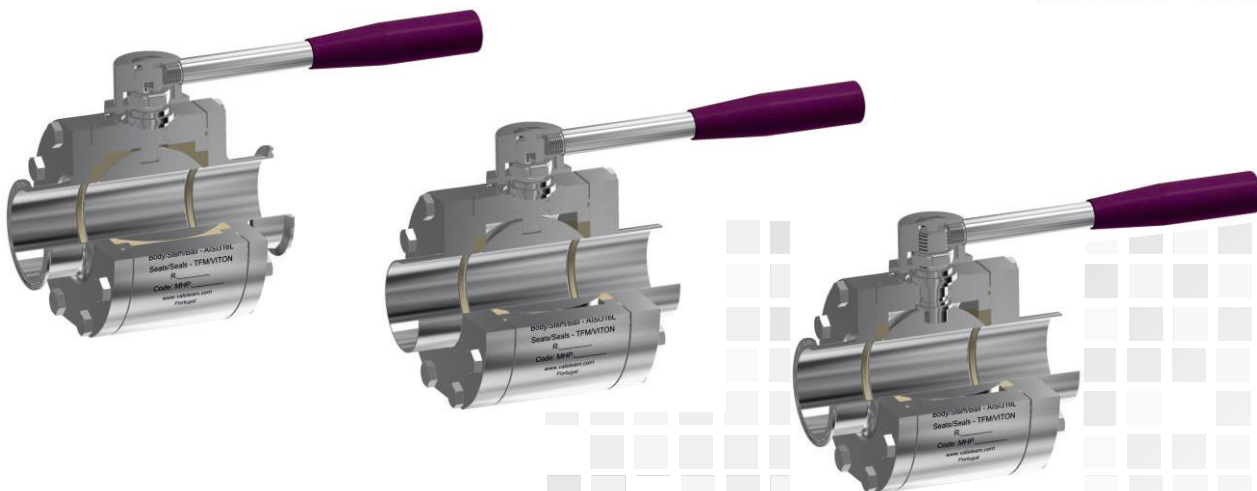
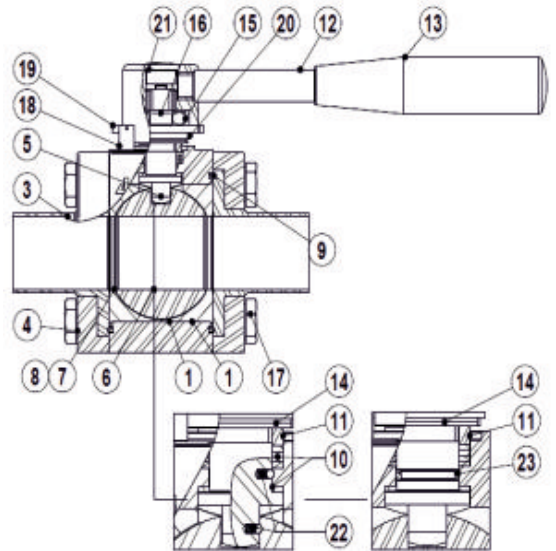
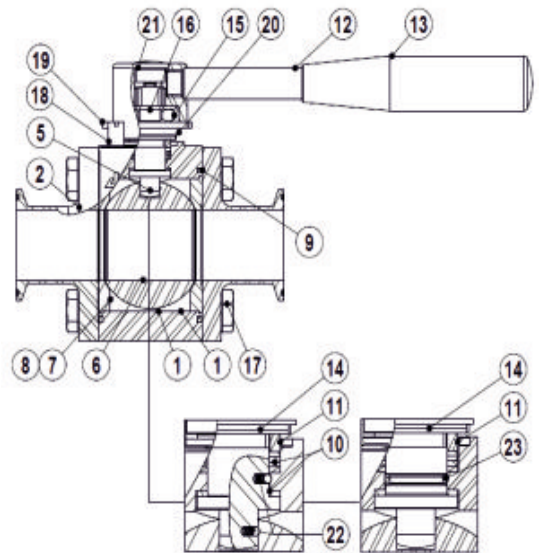

## High Purity Ball Valves M3HP True Bore (2½" - 4" ASME BPE | DN 65-100 DIN)

DIMENSIONS (mm) ASME BPE

SIZE	A1	A2	A3	A3.1	A3.2	B	C	D	E	ØF	ØG	ØH	I	BALL PORT	ISO 5211	WGT. (kg)
2½"	190	203	196,3	95	101,5	160	72,5	130	250	77,5	63,5	60,2	29	60,2	F7	15,3
3"	216	228	222	108	114	180	83,5	140	290	91	76,2	72,9	30	72,9	F7	22,1
4"	254	267	260,5	127	133,5	220	101,5	158	290	119	101,6	97,4	36	97,4	F10	39,7

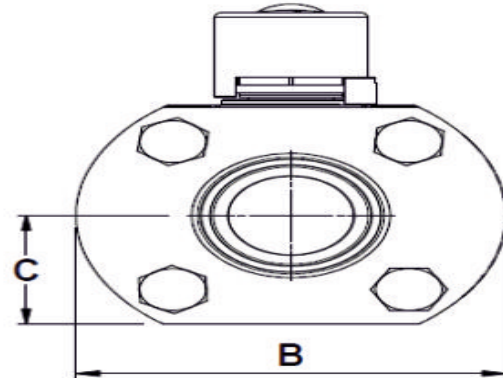
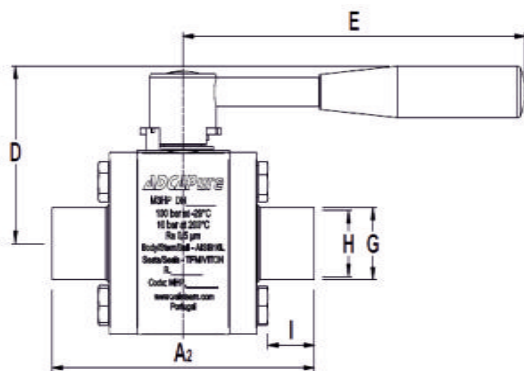
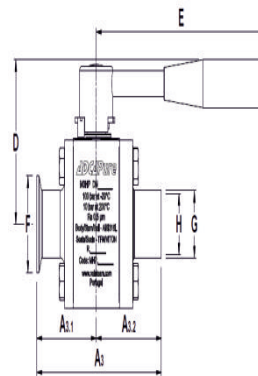
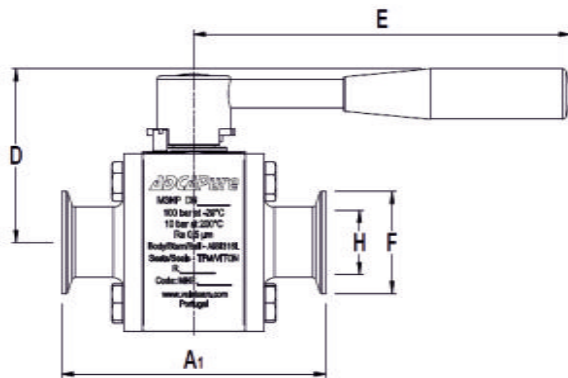

Tube weld easy and quick installation-standard

